



BHC.2.700 equipped with 2DNI unit with inverted half-couplers 3000

Description

Designed for the supply of EGES KRATO type differential double-acting cylinders with separate pump (EKPS), the hand pumps in the BHC range are equipped with automatic dual-flow rate injection pumps enabling instantaneous transition from the fast approach speed to the working speed. Each pump has a two-way manual inverter for push or pull mode, an adjustable internal pressure limiter, and a connector for a pressure gauge.

Specifications

- Working pressure 700 to 1000 bar
- Effective oil tank capacity 1 to 60 litres
- Single-piece light alloy body
- Automatic dual-flow pump with internal pressure limiter
- Two-way manual inverter
- Detachable pumping lever, locking in low position
- Lever high position return spring
- Pressure gauge connector
- Stabilisation lug

On request

- Pressure calibration to other values
- Quick couplers with metal protective cap
- Adjustable external pressure limiter
- Distribution unit for supplying multiple cylinders
- Greater capacity
- Pressure gauge
- Foot-operated control
- Use with Skydrol type fluid

BHC.1 - BHC.2 - BHC.4C - BHC.5C

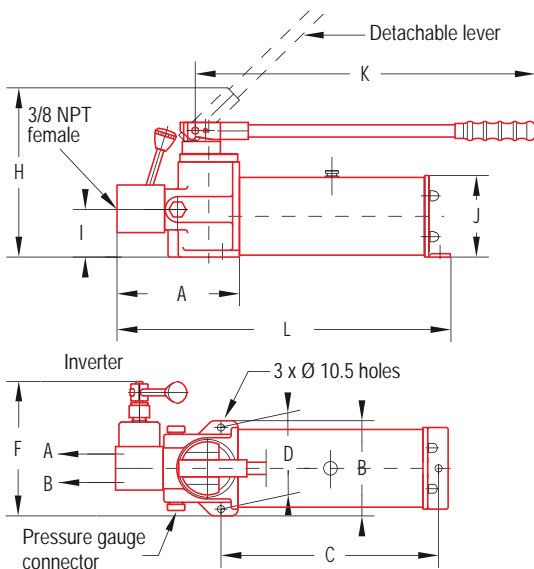

BHC.4 to BHC.60

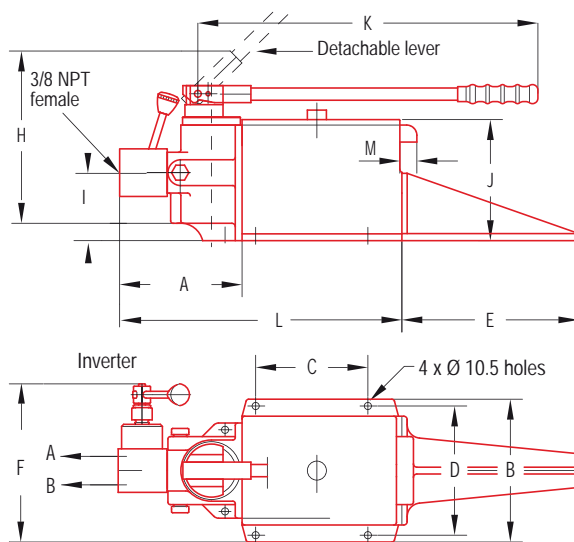

P/N	Mass kg	Eff Cap in litres	Dimensions in mm											Flow rate cm ³ per pump activation				
			A	B	C	D	E	F	H	I	J	K	L	M	700 bar		1000 bar	
															LP	HP	LP	HP
BHC.1	11,5	1,2	160	130	340	110		190	215	55	95	500	495		8,6	1,58	8,6	1,58
BHC.2	14	2	170	140	320	120		195	245	70	116	525	480		21,3	1,85	21,3	1,6
BHC.4.C	19	4	170	140	410	120		195	245	70	135	575	570					
BHC.4	20	4	170	210	165	190	250	230	275	100	178	525	400	26				
BHC.5.C	20	5	170	140	505	120		195	250	70	140	575	665					
BHC.8	24	8	170	250	170	230		250	275	100	178	575	510	26				
BHC.15	40	13,7	170	310	300	280		280	275	100	176	575	620					
BHC.20	46	16,6	170	360	300	330		305	275	100	176	575	620					
BHC.25	55	21,6	170	410	350	380		330	275	100	176	575	670					
BHC.30	64	26	170	410	450	380		330	275	100	176	575	770					
BHC.35	68	28,2	170	410	450	380		330	275	100	176	575	820					
BHC.60	127	56,5	170	560	750	530		405	275	100	176	575	1070					